

ATKINSON, CHRISTEN AND FAUSTMANN HYPSONETERS

Author: Wolf Ruecker

www.plumbbobcollectors.info

Dear Fellow Collector,

Dear reader of the PLUMB BOB NEWS,

Please, as always I am in search of new photos, catalogs, articles or personal stories about any aspect of PLUMB BOBS from you. Any help is appreciated.

If you have any information or pictures for these themes, please let me know.

Thank you, looking forward to hearing from you

Wolf

ATKINSON, CHRISTEN AND FAUSTMANN HYPSONETERS

TABLE OF CONTENTS

1. INTRODUCTION..... 100
2. THE ATKINSON HYPSONETER FROM 1872 ..... 101
3. THE PATENTED CHRISTEN HYPSONETER 1891 ..... 107
4. THE FAUSTMANN MIRROR HYPSONETER 1854 update..... 110
5. SOMETHING TO SMILE ABOUT..... 112
6. REMARKS ..... 112

1. INTRODUCTION

The small plumb bob – the center of our collections – needs only the gravity of the earth for working. No electricity, no other power.

In my collection I have also some instruments called inclinometer or hypsoneter to measure the height of trees or buildings. One of them you know already from my newsletter 2009-04 THE FAUSTMANN MIRROR HYPSONETER. It was invented by the German forester Martin Faustmann in 1854 and uses a small plumb bob to measure the height of trees. About this instrument you will find an update here with new information about the version sold by K&E in the U.S.A. between 1904 and the 1930s and more about different versions of this mirror hypsoneter made by the optician Neuhöfer & Son, Wien, Austria.

But there are also small inclinometers or hypsoneters where the body is nearly working like a plumb bob, only with the gravity force. These are so called pendulum hypsoneters. I will talk about the English Atkinson hypsoneter of 1872 from my collection and the patented Swiss Christen hypsoneter of 1891 from the collection of my friend Ulrich Biber. Both are mentioned in English and American books about forestry.

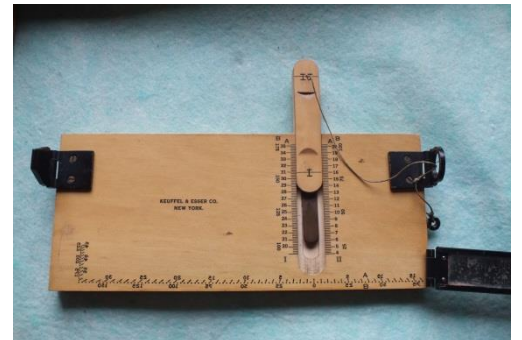

Above: FAUSTMANN mirror hypsoneter made by K&E, NY, U.S.A
Left: CHRISTEN hypsoneter from Switzerland
Below: ATKINSON hypsoneter from England



## 2. THE ATKINSON HYSOMETER FROM 1872

### THE ATKINSON / ROBSON STORY

#### The short story of a GOOD IDEA in 1872 which was POORLY IMPLEMENTED.

While rummaging in my museum, I found a small mahogany box (case) with the (bad) stamped name MH ATKINSON with dimensions 5" x 2¾" x ¾"

Inside was an isosceles triangular brass instrument ATKINSON Hypsometer, manufactured by F. ROBSON 45 DEAN STREET, NEWCASTLE with an interesting operating instructions. Dimensions of the instrument: perpendicular sides 3", hypotenuse 4 ¼" and 1/32" thick. The operator's manual was printed in a triangular shape, which corresponded to the isosceles instrument. The device was in good physical condition but has suffered some chemical attack at one corner which has affected the case, the hinge and the paper of the instruction, so I had to take a closer look at the text to find out the address of the maker.

For the translation from English into German I then retyped the text and discovered a **white spot** in the middle of the text. I thought it was also a water spot (although the text appeared complete to me). For safety's sake, I asked some friends in the U.S.A. They confirmed to me: **There is nothing missing.**

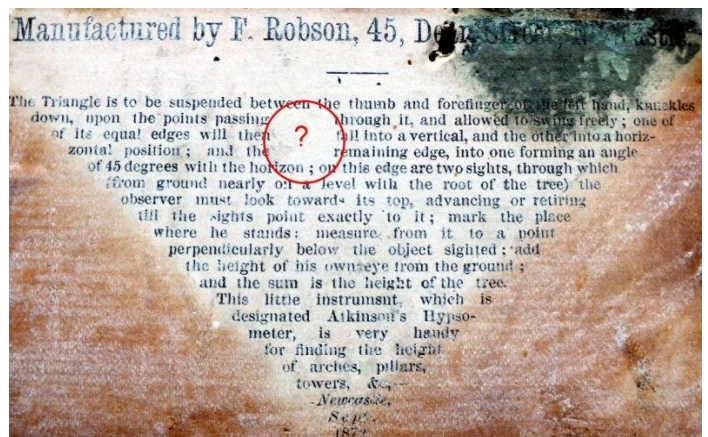
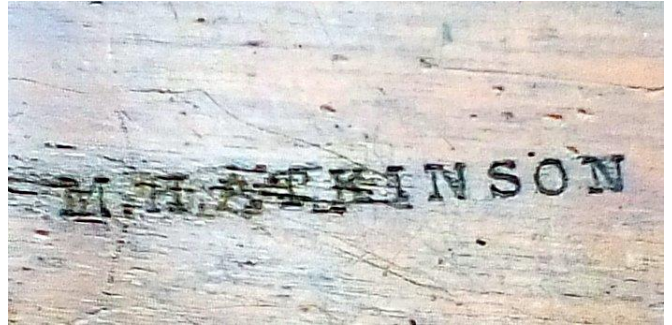

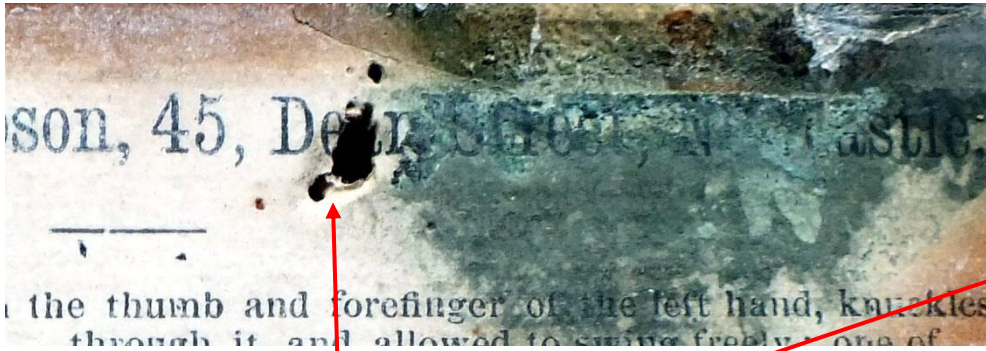

ed between the thumb  
 passing through  
 then fall in  
 d the remain  
 the horizon ; on this  
 nearly on a level w  
 it look towards its

A look through my magnifying glass showed clear text and a "white spot". Such a **white spot** in a manual "screams" to me for an explanation and investigation. The readability of the headline was also influenced by a **large hole** that was caused by one of the two **pins (points)** on which the instrument in use is held between the thumb and the index finger.

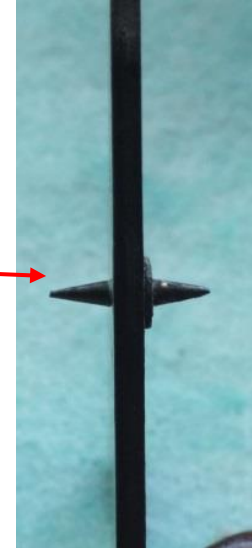

Here are the operating instructions: xxxxxx= white spot  
 "Manufactured by F. Robson, 45 Dean Street  
 Newcastle

The triangle is to be suspended between the thumb and forefinger of the left hand, knuckles down, upon the points passing xxxxxx through it, and allowed to swing freely; one of its equal edged will then xxxxxx fall into vertical, and the other into horizontal position; and the xxxxxx remaining edge, into one forming an angle of 45 degrees with the horizon; on this edge are two sights, (Remark: my instrument has two additional sighting devices on one of the other sides) through which (from ground nearly on a level with the foot of the tree) the observer must look towards its top, advancing or retiring till the sights point exactly to it; mark the place where he stands. Measure from it to a point perpendicularly below the object sighted: add the height of his own eye from the ground; and the sum is the height of the tree. **The little instrument, which is designated Atkinson's Hypsometer, is very handy for finding the height of arches, pillars, towers, &c, Newcastle, Sept, 1872.**"

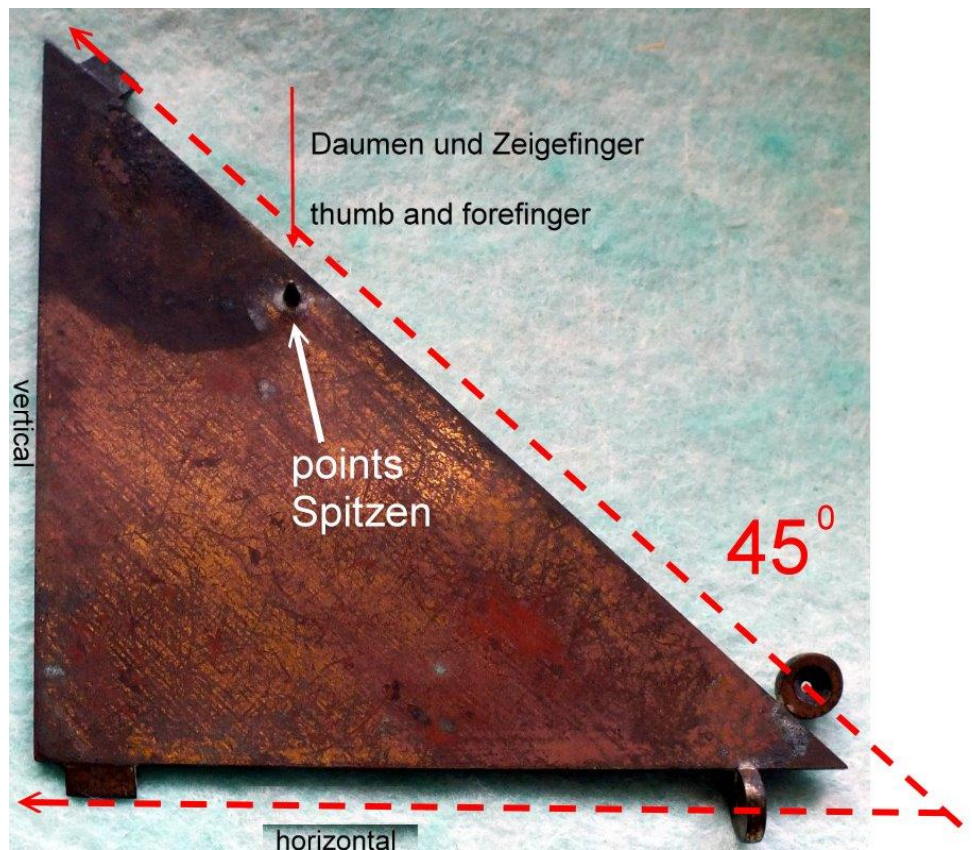

My search on the internet for the ATKINSON Hypsometer led me to two auctions in 2004 and 2010 in England, where this instrument was sold for 75 or 91 British Pounds and to a photo in a “DUNOTTAR COLLECTION”. See photo on the bottom of this page.

Here again a different combination: the operator's manual glued as in my device (only readable on the head when you open up the case), but the instrument has **only two sighting devices**.

In one of the auctions I found a good photo that showed **more significant differences**:

- Only two sighting devices on the hypotenuse (no sights on the other sides)
- Text directly readable if you open the case.
- Shape of the triangle text does not match with the shape of the instrument (see the brighter imprint of the device)
- The pins for the finger have a different position (slightly below and slightly to the right) than on the other instruments. Possibly due to the additional weight of 3<sup>rd</sup> and 4<sup>th</sup> sights. See the comparison below.

However, I noticed herein that the position of the white spot is approximately in the position where the tips are attached to the unit.

(But the tip does not hit the white spot, since the positioning of the glued operator's manual is not correct). See picture below.

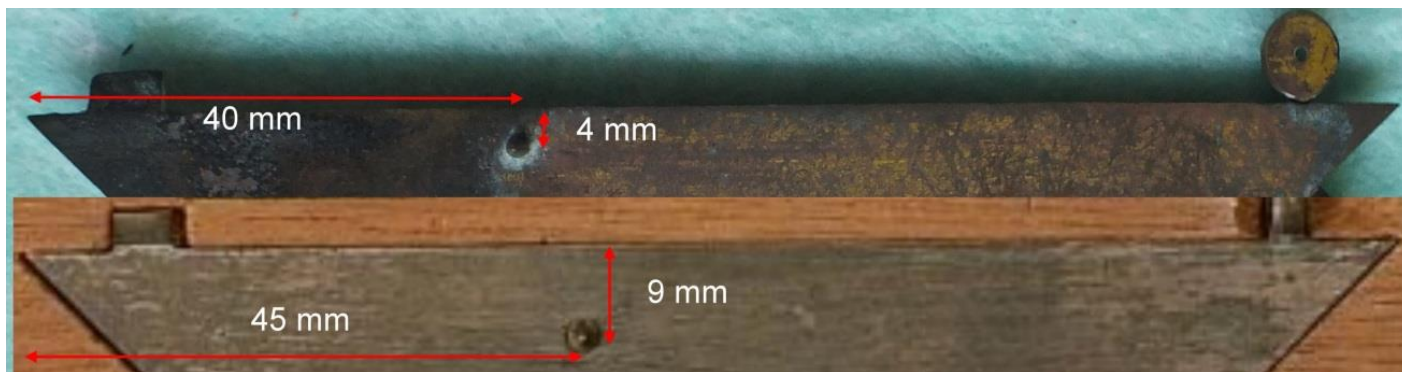

Photo of the Atkinson from then “DUNOTTAR COLLECTION” right.



But here I saw an approach for my further considerations.

So I used my (limited) possibilities of a photomontage and “cut out the images”, “slightly enlarged”, “mirrored”, etc., until I came to the following results:

The “shrewd head”, who had omitted the white spot in the instructions, wanted to achieve the following:

NO DISTURBANCE OF THE TEXT IN THE OPERATION MANUAL THROUGH A HOLE IN THE PAPER CAUSED BY THE PINS!

But here his colleagues in the team, who also worked on the production of this instrument did not understand what he meant! They thwarted his plans. ☹

THE IMPLEMENTATION INTO PRACTICE SHOULD BE MADE IN THIS WAY.

The following **basic conditions** for the hinged case with the hypsometer must be met:

1. When you open the case, the instrument must lie in the lower part (otherwise it falls out of the lid)
2. The operating instructions shall be readable, in the position in which the user opens the case.
3. The tip must hit the free field (white spot) in the text.

FOR THIS PURPOSE, THE FOLLOWING MODIFICATIONS SHOULD BE MADE:

1. **Text** should be **written larger** (intermediate line to headline omitted) to have the same size as the instrument.
2. **Instrument** should have to be inserted **horizontally mirrored** into the lower part of the case that it will match with the text when the case is closed.
3. **Position of the tips** should **not be changed later**. (as has been done in later produced instruments)

**Only then** the tip of the instrument would pierce in the white spot and will not influence the reading.

**This would require the layout of the case shown below (photo montage):**

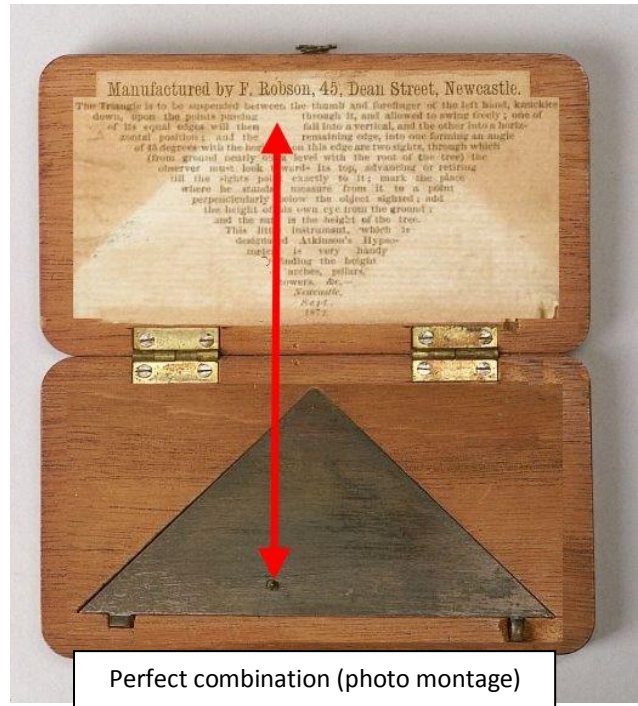

In practice we find, unfortunately, only the versions shown below. **In all these cases the white spot is not hit by the pin** ☹



We know such situations in which holes are pierced in texts through parts of the instruments, for example, at the Bergische Münzwaagen (Bergische coin scales), as my friend Ulrich Biber told me. It was done nearly correct in these examples below.



In GOOGLE BOOKS I found the information below about this instrument, one from a reader of a book 1879 and the other from the inventor himself:

[plumbbobwolf@t-online.de](mailto:plumbbobwolf@t-online.de)

INSTRUMENT FOR MEASURING THE HEIGHT OF TREES.

Sir,—Among the various methods for measuring the height of trees described by Mr. Kay (page 105), I do not observe any notice of a very ingenious and simple little instrument which I have carried for some years,

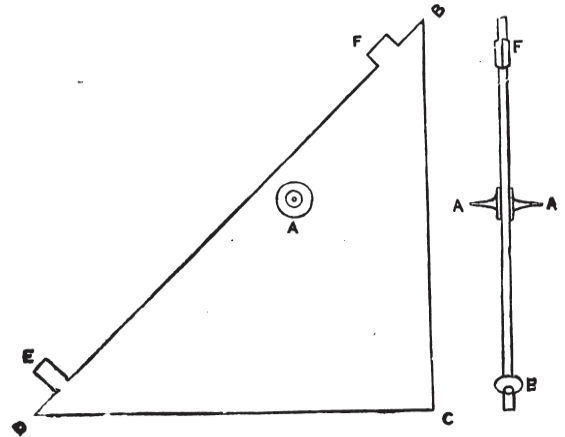

and by which heights of perpendicular objects can be very accurately ascertained. It is called Atkinson's "Hypsometer," and was invented by a gentleman in the neighbourhood of Newcastle. The directions for using the instrument of which the above is an illustration are as follows:—

Suspend the triangle between thumb and forefinger of the left hand, knuckles down, upon the points AA, allowing it to swing freely. The edge BC will then fall perpendicularly, and CD will be horizontal. The remaining edge DB will then lie at an angle of 45° to the horizon. On this edge are two sights, EF. Look through E until F is aligned with the tree top, advancing or retiring till the sight points exactly to it. Then, if the observer's feet are level with the tree root, the height of the tree is the distance from his feet to the root, plus the height of his eye from the ground.

SALMONICKPS.

...and information about Frederick Robson

TRANSACTIONS

OF THE

112176

NORTH-EAST COAST INSTITUTION

OF

ENGINEERS AND SHIPBUILDERS.

1901.

256

MEMOIRS.

MR. FREDERICK ROBSON.

MR. FREDERICK ROBSON was born in Newcastle-upon-Tyne in the year 1844. His father, Mr. Robert Robson, who was a cabinet-maker, was the founder of the firm of Messrs. Robson & Sons, Northumberland Street, Newcastle. On leaving school Mr. F. Robson was apprenticed to Mr. T. B. Winter, optician, Newcastle, on the completion of which he went to London, sought and obtained employment with the well-known firm of scientific instrument makers and opticians, Messrs. W. F. Stanley & Co., London, with the view of further improving himself in his profession.

He afterwards returned to his native city and opened a business in Dean Street. His success was such that in a few years he was obliged to take larger and more commodious premises. He was the inventor of several improvements in surveying and optical instruments.\* He joined this Institution in 1887 as an associate member and took a great though passive interest in its workings. He never took any prominent part in public matters, being of a retiring disposition. His chief hobby was

\* Prior to his death he took into partnership Mr. J. B. Young, who about thirty years ago came to Mr. Robson as an apprentice, afterwards acted as his manager, and by whom the business is now carried on.

VI.—*First Instalment of a Catalogue of the more Remarkable Trees of Northumberland and Durham.*

PRELIMINARY to a Catalogue of the Remarkable Trees of Northumberland and Durham, perhaps I may be permitted to describe a little instrument for ascertaining their height, contrived by me in 1872; which, as it can be obtained of Mr. Winter, of Grey Street, or Mr. Robson, of Dean Street, opticians, for a few shillings, will enable members to supply the girth at five feet from ground, the spread of branches, and the height (which latter has been hitherto rather a difficulty,) of remarkable trees within their observation.

The instrument, as at present made, is a right-angled triangle, with two equal sides or edges (three inches each) cut out of brass plate about one-sixteenth of an inch thick; a pin about half an inch long is fixed through the plate at such a point, that when suspended by it between the finger and thumb, and allowed to swing freely, one of the two equal sides or edges of the plate shall be exactly horizontal; the other will then be perpendicular; and the remaining side at an angle of  $45^{\circ}$  to the horizon.

The mode of using it is to suspend it as above described; and choosing a piece of ground on one side of the tree or other object to be measured, to approach or retire from it, looking along the

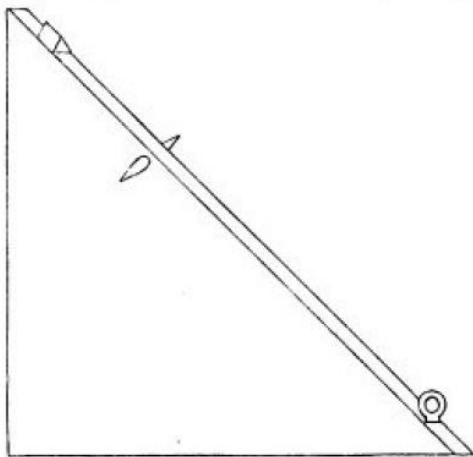

ATKINSON'S HYPSONETER.

sights on the longer side or edge of the triangle towards it until the top of the tree be in an exact line with the sights; mark that place, and measure the distance from it to a point perpendicularly beneath the top (or part of tree of height equal to it); add the height of the eye of the observer from the ground, and the sum is the height of the tree.—*Geo. C. Atkinson.*

At the end one mystery is left: why did they stamp on the lid of the box **M. H. ATKINSON** and not the name of the inventor **Geo. C. Atkinson**?

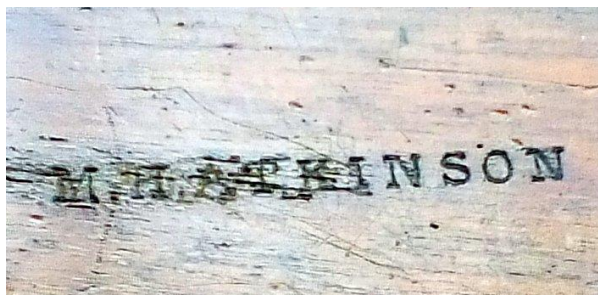

### 3. THE PATENTED CHRISTEN HYSOMETER 1891



Recently my friend Ulrich Biber bought a simple instrument not knowing what it was used for.

He asked me for more information.

The instrument is 33.5 cm long and 2.2 (2.8) cm wide.

The scale is marked non-linear with numbers (in meter).

We only found some words printed on it:

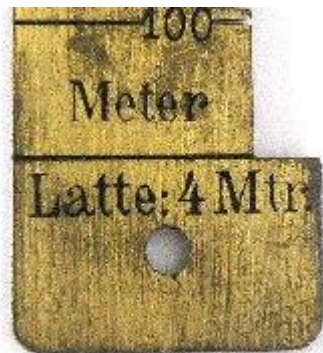

LATTE = POLE 4 meter long

I found references in the www:

PFISTER & STREIT, mathematical and physical workshops in BERN, capital of SWITZERLAND

**This instrument is a tree height measuring instrument, called hysometer.**

It was invented in 1891 by Traugott CHRISTEN, from Bümplitz near Bern, Switzerland:

Patent 3568 May 1896 (see original patent below)



The instrument is delivered in a canvas sheath with an instruction.

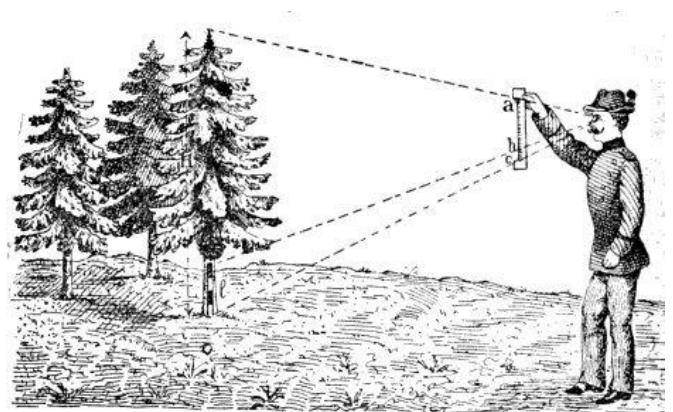

Fig. 19.

Fig. 19: Use of the Christen hysometer (from Stoetzer 1898)

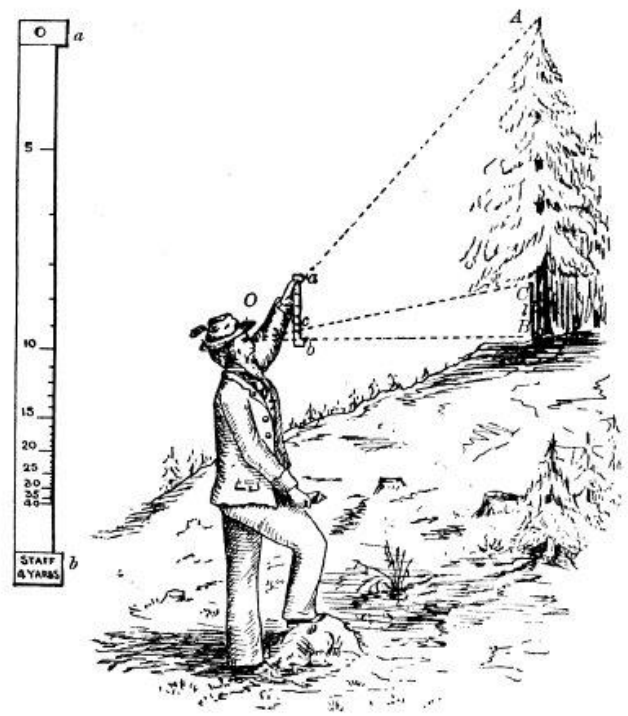

Fig. 16.—Christen's Hysometer.

Fig. 16 from the original instruction



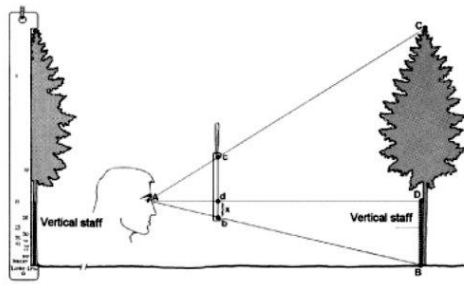

Figure 3-20. Christen hypsoneter.

Text: from FOREST MENSURATION NEW YORK 1921

This instrument consists of a metal strip 16 inches long (unfolded Swiss version 12 1/2 inches), of shape shown in Fig. 51 (column right).

The English/American version is made of two pieces hinged together, which are folded when it is not in use. A hole is pierced in the upper end, from which it is suspended between the fingers. Along the inner edge is a notched scale which gives directly the readings for heights. The instrument is used as follows:

A 10-foot pole (European version 4 meters=13-foot pole) is set against the tree. The observer stands at a convenient station whence he can see the tip and base of the tree and also the top of the 10-foot pole. The instrument is suspended before the eye and moved back and forth until the upper edge is in line of vision to the top of the tree and the lower edge in line of vision with the base. **The point where the line of vision from the eye to the top of the 10-foot pole intersects the inner edge of the instrument indicates on the scale the height of the tree.**

Below the text from FOREST MENSURATION NEW YORK 1921: here the instrument is folded

**198. The Principle of the Christen Hypsoneter.** Many hypsoneters have been invented, principally by Continental foresters, using one or the other of these general principles. The Christen hypsoneter introduces a different principle but has no special merit except the simplicity of its operation. Description of this instrument, taken from Graves' Mensuration is as follows:

This instrument consists of a metal strip 16 inches long, of the shape shown in Fig. 51. The instrument is made of two pieces hinged together, which are folded when it is not in use. A hole is pierced in the upper end, from which it is suspended between the fingers. Along the inner edge is a notched scale which gives directly the readings for heights. The instrument is used as follows: A 10-foot pole is set against the tree. The observer stands at a convenient station whence he can see the tip and base of the tree and also the top of the 10-foot pole. The instrument is suspended before the eye and moved back and forth until the edge *b* is in line of vision to the top of the tree and the edge *c* in line of vision with the base. The point where the line of vision from the eye to the top of the 10-foot pole intersects the inner edge of the instrument indicates on the scale the height of the tree.

Each instrument is constructed for use with a specified length of pole. The instrument described above is one designed by the author for convenience with the use of English units. It was constructed in the following way: The distance *bc* on the instrument was chosen arbitrarily as 15 inches and the length of the pole as 20 feet. It would, of course, be possible to construct an instrument for a pole 12 feet or any other length and on a basis of a desired length of instrument. The theory of the construction of Christen's instrument may be shown by Fig. 52. When used as above described, two pairs of similar triangles are formed: *ABD* and *abc*; *ADC*, and *Adc*, in which  $BC = \frac{bc \times DC}{dc}$  and  $dc = \frac{bc \times D}{BC}$ . With a known value of *DC* and *bc*, *dc* may be determined for different heights which are likely to be required. Thus it may be assumed that it would not be necessary to measure trees less than 20 feet high, so that the lowest graduation on the instrument made for that height. To find the proper point for the 20-foot graduation on the scale, the following formula was used:

$$\frac{BC}{DC} = \frac{bc}{dc} \text{ or } \frac{20}{10} = \frac{15}{dc} \text{ or } dc = \frac{150}{20} = 5.7 \text{ inches.}$$

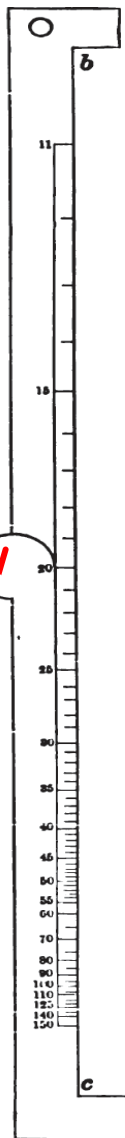

FIG. 51.—The Christen hypsoneter.

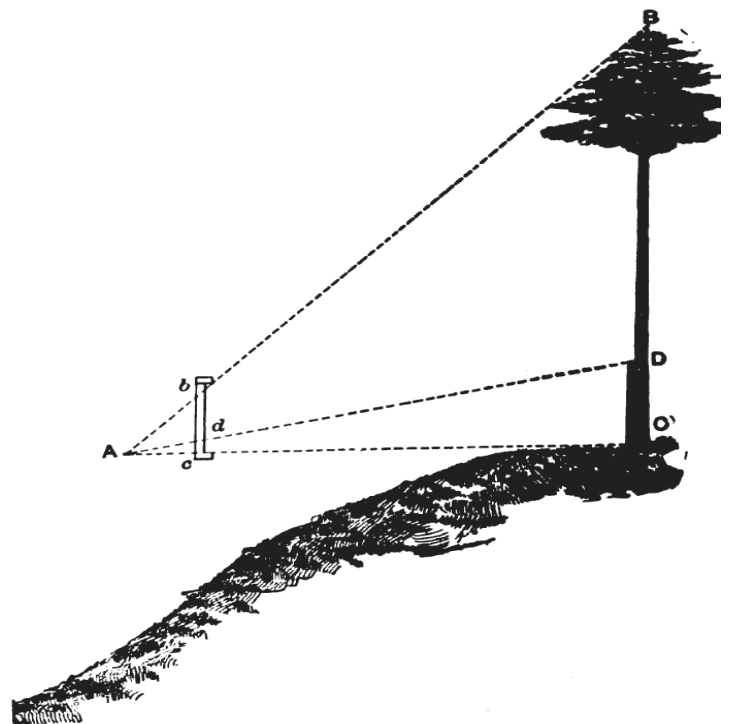
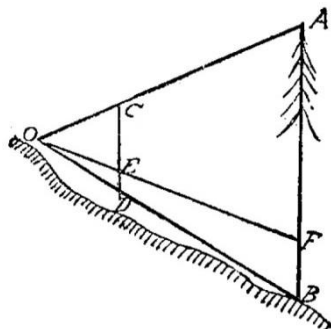

FIG. 52.—Method of application of the Christen hypsoneter.

This same method was used to determine the value of *dc* for a 25-, 30-, 35-, 40-foot tree, etc., up to 150 feet, and the proper graduations made on the scale. The scale is somewhat more easily read when a notch is made at each graduation.

The instrument is light and compact, and with practice can be used very rapidly, provided one has an assistant to manage the 10-foot pole. It requires no measurement of distance from the tree, and the height is obtained by one observation. It is more rapid than either the Faustmann or Weise instrument.

Its disadvantages are that it requires a very steady and practiced hand to secure accuracy, that it cannot be used accurately for tall trees, and that it is not adapted for steady work because it is extremely tiresome to hold the arm in the position required. This last objection may be overcome by using a staff to support the hand.



SCHWEIZERISCHE EIDGENOSSENSCHAFT

EIDGEN. AMT FÜR

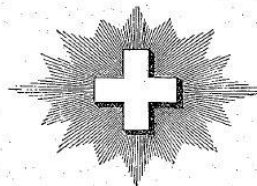

GEISTIGES EIGENTHUM

PATENTSCHRIFT

Patent Nr. 3568

11. Mai 1891, 4 Uhr, p.

Klasse 60

TRAUGOTT CHRISTEN, in BÜMPLIZ bei Bern.

Höhenmaassstab zum Messen von Bäumen.

Der Höhenmaassstab dient zur Bestimmung von Baumhöhen. Er besteht aus einem flachen Metallstab, der oben und unten zweckmässig mit einem als Diopter dienenden Vorsprung versehen ist und eine Eintheilung trägt, an welcher mit Hilfe einer Latte von bestimmter Länge oder einer in entsprechender Höhe am Baume angebrachten Marke direkt die Baumhöhe abgelesen werden kann.

Sein Prinzip ist folgendes:

Sei  $A-B$  der Stamm, dessen Höhe gesucht werden soll,  $C-D$  ein senkrecht hängender Metallstab in solcher Lage, dass das obere Ende  $C$  in der Visurlinie  $O-A$ , das untere  $D$  in der Visurlinie  $O-B$  liegt.  $B-F$  sei eine neben dem Baume stehende Latte oder die Höhe der am Baume angebrachten Marke über dem Boden,  $E$  der Punkt, welchem gegenüber das Auge des Beobachters  $O$  das obere Ende der Latte  $F$  sieht. Man hat dann die Proportion

$$\frac{A B}{F B} = \frac{C D}{E D}, \text{ woraus } A B = \frac{C D \cdot F B}{E D}$$

Für unser Instrumentchen ist beispielsweise  $C-D = 30$  cm,  $B-F$ , die Latte, gleich 4 m. Bestimmt man nun für alle häufigeren Höhen die zugehörige Distanz  $E \cdot D$  aus

$$E D = \frac{C D \cdot F B}{A B} \text{ (hier } \frac{4 \times 0.3}{A B} \text{)}$$

next page

berechnete Maassstab unter Anwendung einer 2 m langen Latte benutzt, so ist das abzulesende Resultat noch durch zwei zu dividieren.

Die wesentlichen Vorzüge dieser Art Messung sind folgende:

1. Das Instrument besteht aus einem einfachen Stab, der sehr leicht mitzuführen ist;
2. Es gestattet eine direkte Ablesung der Baumhöhen;
3. Es macht die Messung einer Standlinie unnöthig, was auf steilem oder mit Unterwuchs bewachsenem Terrain besonders nicht zu unterschätzen ist;
4. Der Gebrauch eines Stativs ist ebenfalls unnöthig;
5. Es verlangt zur raschen Bestimmung nur einen Gehülfen; die übrigen gebräuchlichen Höhenmesser deren zwei;
6. Es erlaubt auch eine Höhermittlung ohne Gehülfen und ohne Stange, wenn man die

und trägt die Resultate direkt an dem Höhenmaassstabe auf, so erhält man z. B. eine Skala ähnlich der des auf beiliegender Zeichnung dargestellten Instrumentchens. Die Theilstriche können zweckmässigerweise im Maassstab eingesägt werden.

Will man mit Hilfe des Höhenmaassstabes eine Baumhöhe bestimmen, so lässt man einen Gehülfen eine (in obigem Beispiele 4 m lange) Latte senkrecht neben dem Baum so aufstellen, dass Latte und Stammaxe gleich weit vom Beobachter entfernt sind, oder man bringt am Baume selbst in entsprechender Höhe eine Marke an. Alsdann bringt man den leicht in der linken Hand zwischen Daumen und Zeigefinger vertikal hängenden Maassstab in eine solche Lage, dass die Visur nach dem Gipfel des Baumes den Punkt  $C$  der Zeichnung, diejenige nach dem Fuss desselben den Punkt  $D$  tangirt, und hält dann diese Lage möglichst fest, was mit Hilfe eines Bergstockes noch in der Weise bedeutend erleichtert wird, dass man solchen mit den drei äusseren Fingern fasst, während Daumen und Zeigefinger den Maassstab beim Loch halten. Schliesslich visirt man nach dem obren Ende der Latte oder nach der Marke und liest am Maassstabe die Höhe in Metern ab. Wurde der nach obigem Beispiel

ganze Länge des Maassstabes, die in unserm Beispiel 33,33 cm beträgt, z. B. sechs Mal aufträgt und in dieser Höhe mit dem Baumreisser oder dergleichen eine deutliche horizontale Kerbe macht und diese statt dem obren Ende anvisirt.

PATENT-ANSPRUCH:

Der Höhenmaassstab zum Messen von Bäumen besteht aus einem leichten, flachen Stabe aus Metall oder anderem geeignetem Material, an welchem sich eine Eintheilung befindet, die mit Hilfe einer, an dem zu messenden Baume aufgestellten Latte von bekannter Länge, oder eines am Stamme in bekannter Höhe angebrachten Merkmals direkt die Höhe des betreffenden Baumes angibt, ohne dass eine Standlinie gemessen zu werden braucht.

TRAUGOTT CHRISTEN.



#### 4. THE FAUSTMANN MIRROR HYPSONETER 1854 update

The basic information of the FAUSTMANN mirror hypsoneter you will find on my web site on subpage "Faustmann mirror hypsoneter" with the direct link:

<http://www.plumbbobcollectors.info/60822.html>

or in my newsletter 2009-04.

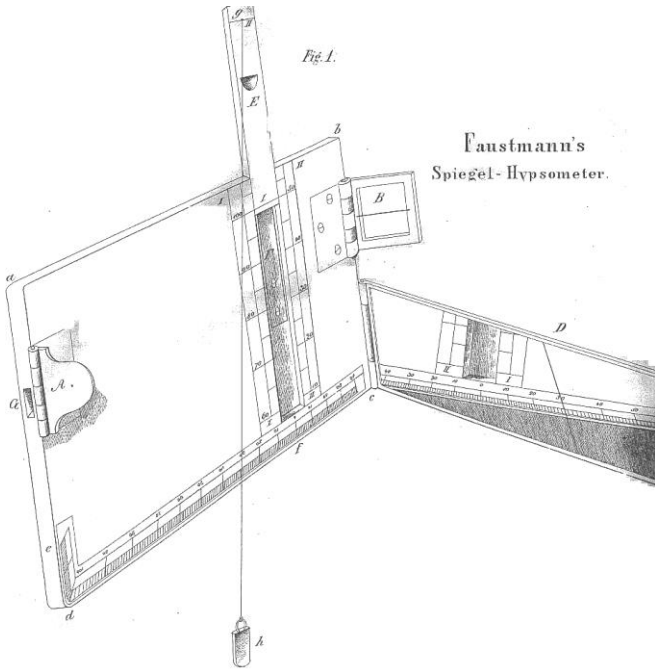

The first drawing of the mirror hypsoneter from a newspaper 1856



Original Faustmann hypsoneter produced by Martin Faustmann and his wife in the 1860s from my collection.

Recently I could buy from a seller in Beaufort, South Carolina a Faustmann mirror hypsoneter made by Keuffel & Esser K&E in NY. It was THE FIRST AND ONLY instrument that I saw after 5 years searching for an American made mirror hypsoneter. When YOU have such an instrument in your collection, please let me know. I knew that K&E offered that instrument between 1905 and the 1930s in the catalogues in two versions: one from BRASS and one with a WOODEN body. See drawings below.

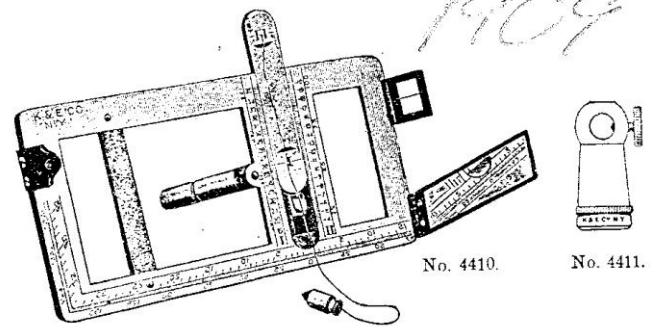

4410. Hypsoneter  $3\frac{1}{2} \times 7$  in., (after Faustmann), brass, graduated surface silvered, hinged mirror mounted in aluminum, folding sights, folding swiveling handle. In cloth covered pouch  $3\frac{1}{2} \times 7\frac{1}{2} \times \frac{1}{2}$  in. with cover flap. With Directions . . . . . each \$19 50  
4410S. Sole Leather Pouch for No. 4410, . . . . . extra " 2 00

This Hypsoneter is provided with two scales: the scale of heights on the lower edge of the instrument and the scale of distances on the two edges of the groove in which the slide moves. The slide carries the plumbbob thread and has two reading lines marked I and II, corresponding to the two scales of distances also marked I and II. It is held in place by a spring. The plumbbob is stored in a small tube at the back of the frame. The peep-hole and hairline sights and mirror ( $5\frac{1}{4} \times \frac{1}{4}$  in.) are hinged to fold down.

4411. Brass Ferrule, to fit Gimlet Support, (No. 4402, p. 469).  
or staffhead . . . . . each \$ 1 00

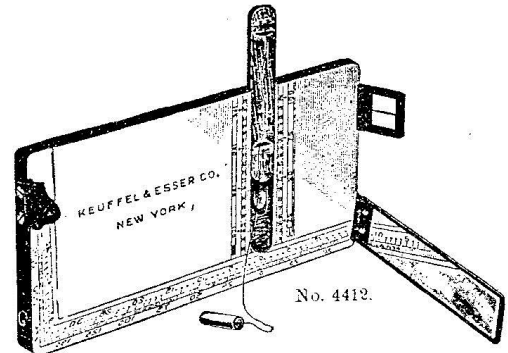

4412. Hypsoneter (after Faustmann), like No. 4410, but of polished hardwood, graduations on white facing with protective coating, hinged mirror mounted in aluminum, folding sights. In cloth covered pouch  $3\frac{1}{2} \times 7\frac{1}{2} \times \frac{1}{2}$  in. with cover flap. With Directions, . . . . . each \$ 6 50

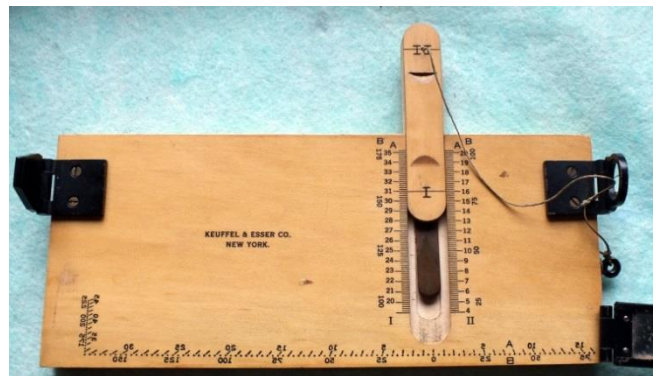

**KEUFFEL & ESSER CO.  
NEW YORK.**

On the front it is marked with the company name and on the back the former owner burned his name in. The seller told me: "The original owner was the dean of forestry at New York College."

**N.Y. COLLEGE FORESTRY F. M.**



The instrument was sold in a black card board case. The button is marked with the company name.



My plumb bob has another (better) shape than the simple cylindrical lead plumb bob shown in the catalogue. So it seems to be younger.



Also the position of the "garage" is different: In the catalogue the "garage" is on the left side and on my instrument on the right side.

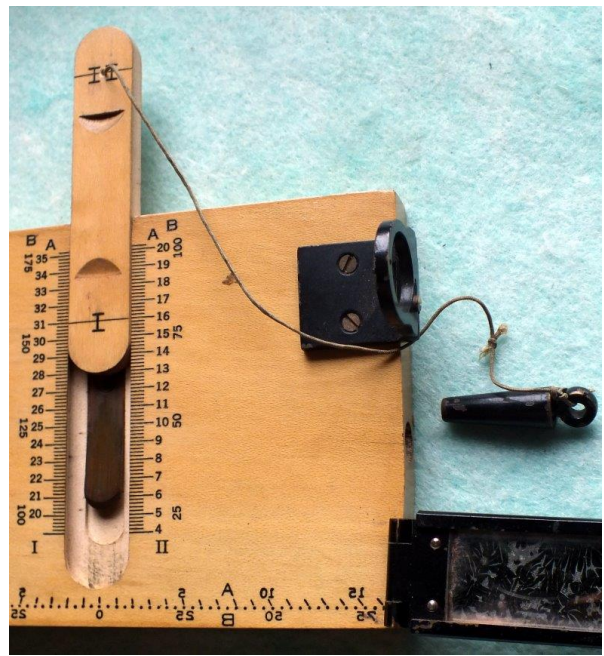

The two vertical (distance) scales are marked as follows:  
II 4 to 20 (for the horizontal height scale A) and 25 to 100 (for the horizontal height scale B) and I from 20 to 35 (for scale A) and From 100 to 175 (for scale B)

The numbers on the horizontal (height) scale are printed mirrored. That is necessary that the user can read the numbers in the mirror correctly.

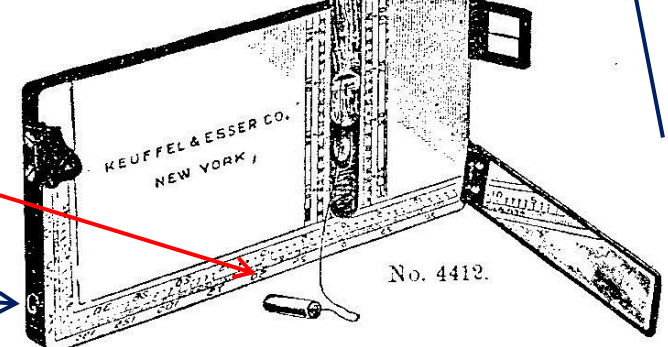
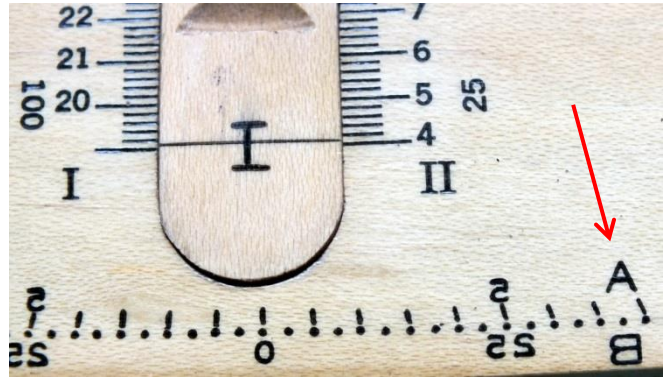

**NEUHÖFER & SOHN maker of a reproduction of the Faustmann mirror hypsometer in WIEN, AUSTRIA**

The instruments of this manufacturer are identified by

- A special hinge (screw)
- A cross hair instead of hair line

The reproduction of the original Faustmann hypsometer by Neuhöfer & Son could be between 1872 (change from foot to meter) and the 1925s (End of the business)

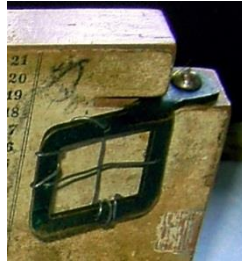

There exist a lot of company markings on the hypsometers. I try to bring them into a chronological order.



No maker name, but typical “Neuhöfer”

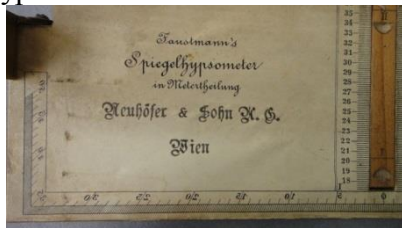

Without the street address



This first **shop** address in the 1<sup>st</sup> district of Wien is mentioned since the 1860s also for the predecessor company Joseph Neuhöfer. Wien I. Kohlmarkt 8

**6. REMARKS**

This is an article of the monthly published WOLF'S PLUMB BOB NEWS that is sent on demand as PDF-file attachment by email. FREE.

You can see all former publications on the website

[www.plumbbobcollectors.info](http://www.plumbbobcollectors.info)

On subpage “download publications” or on page “WHAT’S NEW?”

Remarks and contact by email: [plumbbobwolf@t-online.de](mailto:plumbbobwolf@t-online.de)

Enjoy it

Wolf

Ps. For the members of our group **the whole world turns around the plumb bob** as shown in our logo right. ☺



Logo of the International Plumb Bob Collectors Association IPBCA

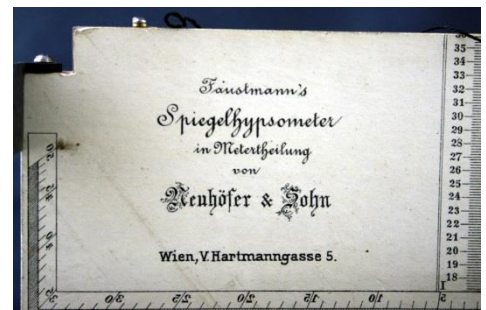

In **1905** Neuhöfer moved the **shop** from the 1<sup>st</sup> district to the 5<sup>th</sup>: WIEN, V. Hartmannngasse 5. Near to the factory in WIEN, V. Schlossgasse 1. Other instrument with similar font, but without name and address hat an instruction with the address Hartmannngasse 5:



Other font, not so squiggled (estimation 1910s)

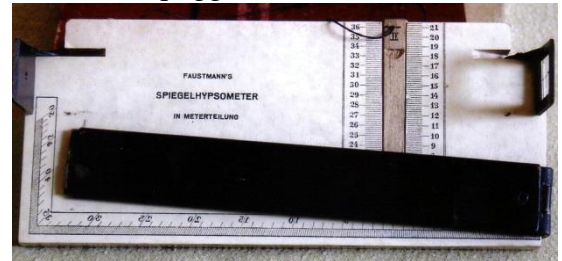

This instrument (without Neuhöfer name) was used in an Austrian forestry school until it was closed in the 1980s

**5. SOMETHING TO SMILE ABOUT**

Could be a sign for the room with your collection of plumb bobs.

